



Comparative analysis of rectangular and circular microstrip patch antenna with slot using modified ground plane technique for UWB applications

Manish Parihar

Lecturer, Department of Electronics Engineering, Government Polytechnic College, Jalore, Rajasthan, India

Abstract

This paper is about Comparative Analysis of Rectangular and Circular Microstrip Patch Antenna with slot using modified ground plane technique for UWB applications. Rectangular Microstrip patch antenna with rectangular slot and Circular Microstrip Patch Antenna with circular slot is designed for Ultra Wide Band Application. Then comparative analysis of both antenna is done in terms of Return Loss, VSWR, Gain, Directivity and Bandwidth of antenna. Microstrip feedline of 50Ω characteristic impedance is used to feed the patch. Modified ground plane technique is used to convert narrow band characteristics of Microstrip Patch antenna into wide band characteristics. FR-4 Epoxy Dielectric Substrate is used for design having $\epsilon_r = 4.4$ and having standard thickness of 1.58mm. The design was optimized by using CST Microwave Studio TM 2011 software to obtain most suitable configuration in terms of desired value of Return Loss, VSWR, Gain, Directivity and Bandwidth of antenna.

Keywords: Circular & Rectangular Microstrip Patch Antenna, Modified ground plane technique, UWB, Bandwidth, Return Loss, VSWR, Gain

1. Introduction

Now day's wireless gadgets has become a part of human life. Many electrical and electronic devices around us are using wireless system to communicate or operate. Antenna is an essential unit of wireless system which radiates electromagnetic waves into the space by converting electric power given at the input into the radio waves. At the receiver side antenna again receive these radio waves and convert them back into the electrical power [1-2]. Antenna is widely used in cellular phones, smart phones, satellite communications, DTH service, spacecraft, radars, wireless door phones, laptops, tablets and wireless computer networks [3]. Microstrip antennas are perfect for these application as it is light weight and can be easily integrated into antenna arrays or into microwave printed circuit boards. But these have a major drawback of narrow frequency bandwidth [2]. Today's wireless system works over wide band of frequency [4] and hence the antenna should be capable for the same. In this paper, an attempt is made to compare simulated results of Rectangular Microstrip patch antenna with rectangular slot and Circular Microstrip Patch Antenna with circular slot for Ultra Wide Band Application. By using techniques like modified ground plane technique or partial ground plane [5], slotting the patch, etc wide band characteristics have been observed [6]. In microstrip antenna, a metallic layer of particular shape is bonded on a dielectric substrate which forms a radiating element and another continuous metallic layer on the other side of substrate as ground plane. Not only the basic shapes but any continuous shape can be used as the radiating patch [7]. For satisfactory performance of antenna Return Loss (R.L) < -10dB and VSWR < 2 throughout the entire ultra wide band

range [8].

2. Description of Work

A narrow band Rectangular Microstrip patch antenna with rectangular slot and Circular Microstrip patch antenna with circular slot is designed. Then using modified ground plane technique i.e. partial ground plane technique, wide band characteristics for both design is observed by changing the parameters like length, width of antenna and length, width of ground plane. After that comparative analysis of both designs for Return Loss, VSWR, Gain, Directivity and frequency bandwidth is done. Performance Analysis of designed antenna has been optimized in CST Microwave Studio TM 2011 software which utilizes finite Integration Technique for Electromagnetic Computation [9].

3. Antenna Design Configuration

3.1 Rectangular Microstrip Patch Antenna with rectangular slot on patch and its description

Rectangular Microstrip Patch Antenna with rectangular slot on patch is shown in Fig 1. Modified ground plane technique is used in place of ground plane to convert narrow band antenna into wide band antenna. FR-4 Epoxy Dielectric Substrate is used for design having $\epsilon_r = 4.4$ and having standard thickness of 1.58mm. Microstrip feedline of 50Ω characteristic impedance is used to feed the patch. The antenna design process is started by initially taking 8.2 GHz as resonant frequency. Performance of designed antenna has been optimized by varying the parameters of antenna given below in table 1.

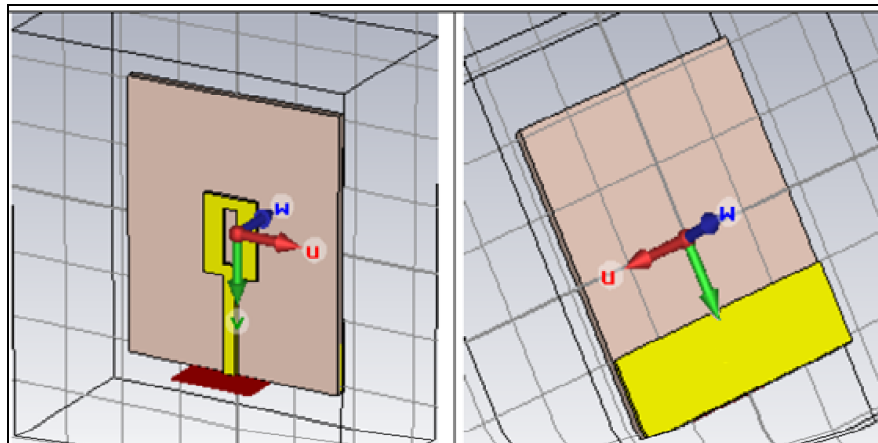

Fig 1: Front and back view of Rectangular Microstrip Patch Antenna with rectangular slot on Patch.

Table 1: represents Dimension of designed Rectangular Microstrip Patch Antenna with rectangular slot on Patch.

Parameters	Description	Value(mm)
Lf	Length of feedline	7
Wf	Width of feedline	2
L1	Length of slot	5
W1	Width of slot	2
Lsub	Length of substrate	17
Wsub	Width of Substrate	20
Lp	Length of Patch	8
Wp	Width of Patch	11
Lg	Length of ground plane	4
Mt	Thickness of Patch	0.07
h	Thickness of Substrate	1.58

Table 2: represents Dimension of designed Circular Microstrip Patch Antenna with circular slot on patch.

Parameters	Description	Value(mm)
Lsub	Length of substrate	18
Wsub	Width of Substrate	12
Lf	Length of feedline	7
Wf	Width of feedline	2
a	Radius of Circular patch	5
Mt	Thickness of patch	0.07
h	Thickness of substrate	1.58
Lg	Length of ground plane	4
b	Outer slot radius	2
c	Inner slot radius	1

3.2 Circular Microstrip Patch Antenna with circular slot on patch and its description

Circular Microstrip Patch Antenna with circular slot on patch is shown in Fig 2. Modified ground plane technique is used in place of ground plane to convert narrow band antenna into wide band antenna. FR-4 Epoxy Dielectric Substrate is used for design having $\epsilon_r = 4.4$ and having standard thickness of 1.58mm. Microstrip feedline of 50Ω characteristic impedance is used to feed the patch. The antenna design process is started by initially taking 8.2 GHz as resonant frequency. Performance of designed antenna has been optimized by varying the parameters of antenna given below in table 2

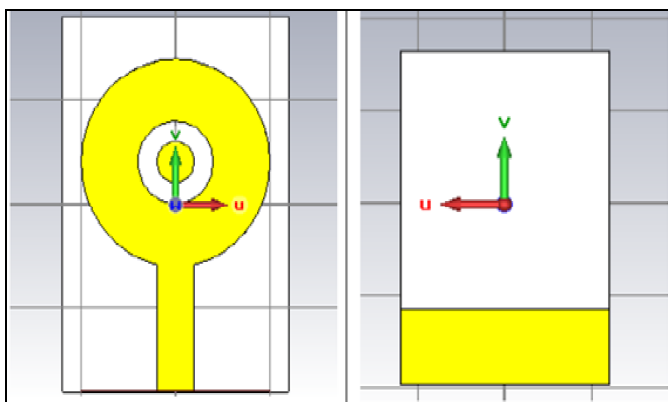

Fig 2: Front and back view of Circular Microstrip Patch Antenna with circular slot on patch.

4. Result and Discussion

The return loss, VSWR, gain and directivity plot of both designed antenna for resonant frequency of 8.2 Ghz is shown below.

4.1 Rectangular Microstrip Patch Antenna with rectangular slot on patch

The return loss, VSWR, gain and directivity of designed antenna for resonant frequency of 8.2 Ghz is shown below in Fig 3. (a, b, c, d) respectively. It is observed that design achieves the return loss of -11.25 dB and bandwidth of 7.3 GHz (3.87- 11.17GHz) for resonant frequency of 8.2 Ghz and corresponding VSWR is 1.75. The design antenna have Gain of 3.71 dB and Directivity of 4.58 dB. These results make it suitable for UWB application.

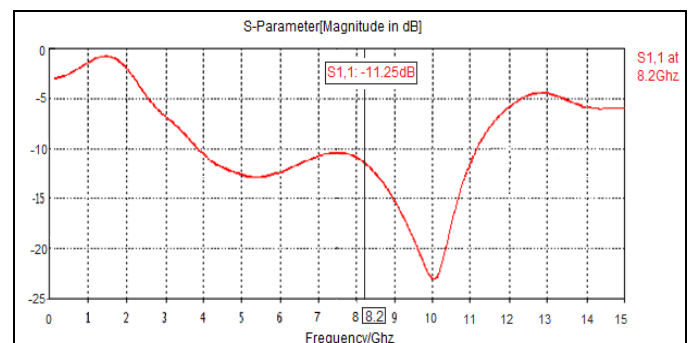

Fig 3(a): Return Loss versus Frequency Plot, Return Loss = -11.25 dB

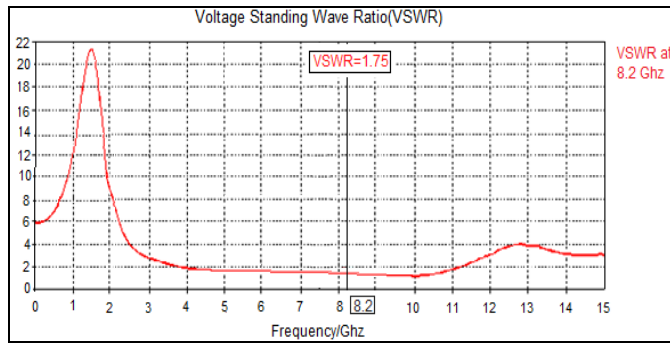

Fig 3(b): VSWR versus Frequency Plot, VSWR=1.75

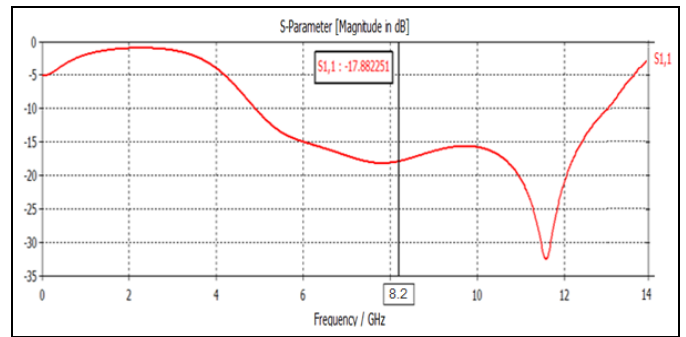

Fig 4(a): Return Loss versus Frequency Plot, Return Loss = -17.88 dB

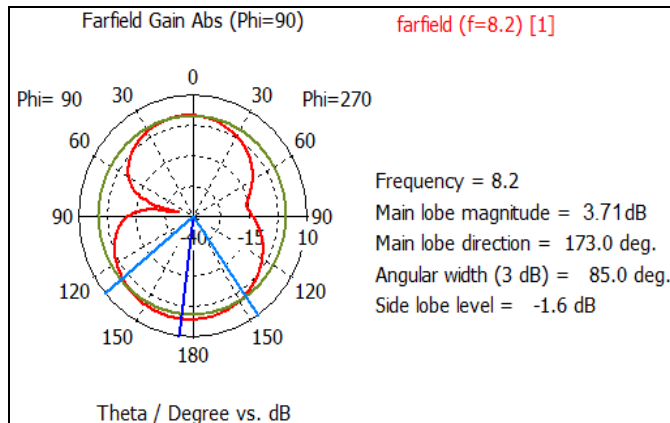

Fig 3(c): Gain= 3.71 dB 2D Radiation pattern plot for

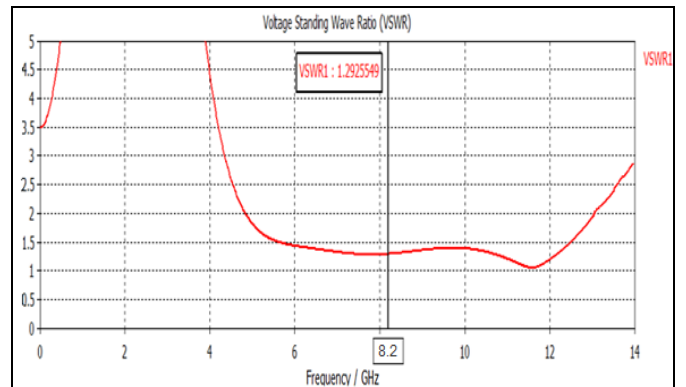

Fig 4(b): VSWR versus Frequency Plot, VSWR =1.29

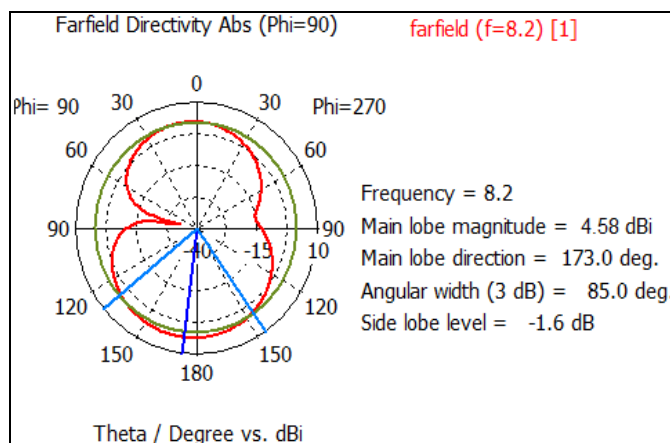

Fig 3(d): Directivity = 4.58 dB

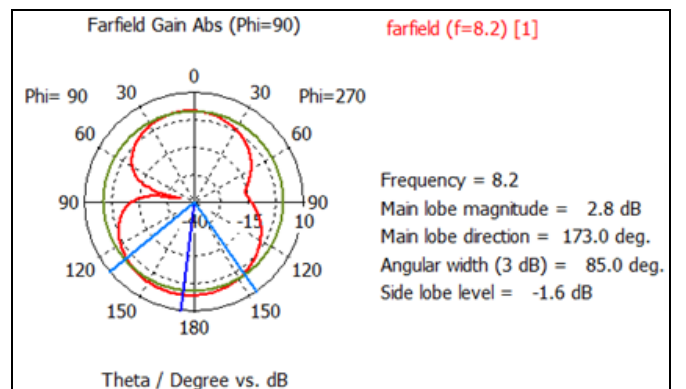

Fig 4(c): Gain= 2.8 dB 2D Radiation pattern plot for.

4.2 Circular Microstrip Patch Antenna with circular slot on patch

The return loss, VSWR, gain and directivity of designed antenna for resonant frequency of 8.2 GHz is shown below in Fig 4.(a, b, c, d) respectively.

It is observed that the design achieves return loss of -17.88 dB and the bandwidth of 8.11 GHz (4.89 - 13.0GHz) and corresponding VSWR is 1.29. The design antenna has Gain of 2.8 dB and Directivity of 3.5 dB. These results make it suitable for UWB application.

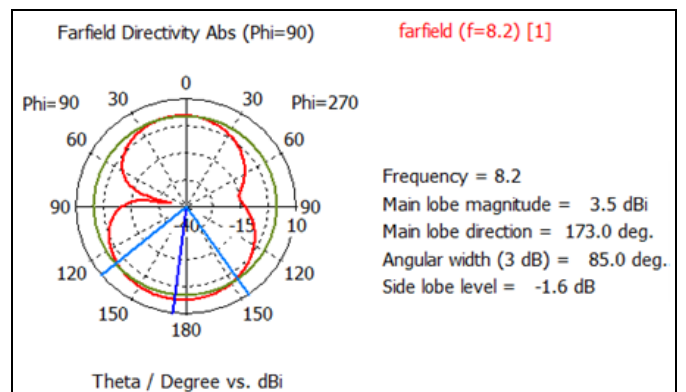

Fig 4(d): Directivity = 3.5 dB

4.3 Comparison and Analysis of Simulated Result

The results of design are compared in below table3

Table 3: represents Comparison of Simulated Result

Antenna Parameter	Rectangular Patch Antenna with rectangular slot	Circular Patch Antenna with circular slot
Return Loss	-11.25 dB	-17.88 dB
Bandwidth	7.30 Ghz	8.11 Ghz
VSWR	1.75	1.29
Gain	3.71dB	2.8 dB
Directivity	4.58 dB	3.5 dB
Area of Patch	88mm ²	78.54 mm ²

1. Circular Microstrip Patch Antenna provides better Return Loss and Bandwidth as compared to Rectangular Microstrip Patch Antenna for equivalent design parameter, operating at same resonant frequency.
2. Circular Microstrip Patch Antenna is more compact and occupy 10.75 % less space as compared to Rectangular Microstrip Patch Antenna for equivalent design parameter, operating at same resonant frequency.
3. Circular Microstrip Patch Antenna has better radiation efficiency as compared to Rectangular Microstrip Patch Antenna for equivalent design parameter, operating at same resonant frequency.
4. Circular Microstrip Patch Antenna is comparative better option for omnidirectional purposes in small handheld wireless devices for UWB Applications.
5. Rectangular Microstrip Patch Antenna is comparative better option for directional purposes due to its high gain and directivity.
6. Circular microstrip patch antenna provides better characteristics & performance and enhances the concept of miniaturization as compared to rectangular microstrip patch antenna.

5. Conclusion

In this paper, circular microstrip patch antenna with circular slot is designed and simulated over CST microwave studio. Following conclusions can be made on the basis of above study:-

1. Rectangular Microstrip Patch Antenna with rectangular slot design attains return loss of -11.25dB, bandwidth of 7.3 Ghz (3.87 - 11.17GHz) and corresponding VSWR is 1.86 and hence can be used for UWB applications.
2. Circular Microstrip Patch Antenna with circular slot on patch design achieves the return loss of -17.88 dB, bandwidth of 8.11 GHz (4.89 - 13.0GHz) and corresponding VSWR is 1.29 and hence can be used for UWB applications.
3. Circular Microstrip Patch Antenna provides better Return Loss and Bandwidth as compared to Rectangular Microstrip Patch Antenna for equivalent design parameter, operating at same resonant frequency.
4. Circular Microstrip Patch Antenna is more compact and occupy 10.75 % less space as compared to Rectangular Microstrip Patch Antenna for equivalent design parameter, operating at same resonant frequency.
5. Circular Microstrip Patch Antenna has better radiation

efficiency as compared to Rectangular Microstrip Patch Antenna for equivalent design parameter, operating at same resonant frequency.

6. Circular Microstrip Patch Antenna is comparative better option for omnidirectional purposes small handheld wireless devices for UWB Applications.
7. Rectangular Microstrip Patch Antenna is comparative better option for directional purposes due to its high gain and directivity.
8. Circular microstrip patch antenna provides better characteristics & performance and enhances the concept of miniaturization as compared to rectangular microstrip patch antenna.

6. Acknowledgement

The above work was carried out by author during his masters at M.B.M Engineering College Jodhpur under the direction of his esteem Prof. & Head (Dr.) V. S. Chauhan, Department of Electronics & Communication Engineering, M.B.M Engineering College Jodhpur. The author expresses his deep indebtedness for his valuable guidance throughout the work. I would also like to thank Mr Kulbhushan Prajapati, Scientist 'D' D.R.D.O Jodhpur for his valuable practical & technical support, and encouragement that he gave me from time to time during the preparation of this work.

7. References

1. Balanis CA. Antenna Theory Analysis and Design, 3rd Edition, New Jersey, John Wiley and Sons, 2005.
2. Ramesh Garg, Prakash Bharti, Inder Bahl, Apisak Ittipiboon. Microstrip Antenna Design Handbook, Artech House Inc. Norwood, MA. 2001; 1(68):253-316.
3. Sana Ullah, Murad Ali, Md. Asdaque hussain, kyung sup kwak. Applications of UWB Technology, IEEE, 2010.
4. Suhana Rashid, Chandan Kumar Chakrabarty. Bandwidth Enhanced Rectangular Patch Antenna Using Partial Ground Plane Method For WLAN Applications. The 3rd National Graduate Conference Nat Grad 2015, Tenaga National University, Putrajaya Campus, Malaysia, 2015, 8-9.
5. Parul Bansal, Ekambir Sidhu, Sonia Goyal. Comparative Study of Notched Circular Slotted and Rectangular Slotted Microstrip patch antennas MPA for wideband applications National Conference on Advances in Engineering and Technology, IJERA ISSN: 2248-9622, 2014.
6. Abhishek Viswanathan, Rajasi Desai. Applying Partial-Ground Technique to Enhance Bandwidth of a UWB Circular Microstrip Patch Antenna IJSER, 2014, 5(10). ISSN 2229-5518.
7. Gary Breed. An introduction to DGS in Microstrip Circuits, High frequency Electronics Summit Technical Media, LLC, 2008.
8. Mishra S, Wankhade P, Sahu A. Design and analysis of T and U shaped slots with truncated corner rectangular microstrip patch antenna for return loss enhancement, 2016 Symposium on Colossal Data Analysis and Networking (CDAN), Indore, 2016, 1-7, doi: 10.1109/CDAN.2016.7570902
9. <https://www.cst.com/products/cstmws>