

Simulation of distributed power system using RTDS

¹ Prem Nath Verma, ² Prem Narayan, ³ BK Singh, ⁴ KS Verma

¹ EED, Rajkiya Engineering College, Bijnour, Uttar Pradesh, India

² EED, Rajkiya Engineering College, Ambedkarnagar, Uttar Pradesh, India

³ Professor, EED KEC, Dwarahat, Uttarakhand, India

⁴ Professor, EED KNIT, Sultanpur, Uttar Pradesh, India

Abstract

It is becoming most important to accurately model and analyze distribution systems. Because day per day it becoming more complex. The number of users are increasing very fast so distribution system is becoming very large. Every node in the distribution system is important because many users are connected to a single node. So it is very important to model a power distribution system with all components for analyzing all the condition and for future planning. For analyzing the distribution data the REAL TIME DIGITAL SIMULATOR is now a complete digital system. Thanks to the progress accomplished in the area of Real Time Computation. This digital simulator, called RTDS is equipped with an integrated system combining real-time and off-line software.

Keywords: dc-dc converter, boost converter, fuel-cell, voltage, efficiency

Introduction

In this paper IEEE 123 Node test feeder for simulation and analysis using RTDS is taken. The IEEE 123 node test feeder operates at a nominal voltage of 4.16 kV. This system is large enough and somewhere seems like a real type distribution system. This system consist all the similarities of a real system like 3 phase feeders, single phase feeders, underground cable feeders, Circuit breakers, 1 phase and 3 phase regulators, transformers, shunt reactors etc [1, 2]. There are 12 line configurations in 123 node feeder. All the nodes are supplying different load. This feeder behaves well and does not have a

convergence problem. It gives a test of the modeling of the phasing of the lines. The four voltage regulators provide a good test to assure that the changing of individual regulator taps is coordinated with the other regulators [3].

Loading of the system is 3 phase (balance or unbalanced) and single phase. Three-phase loads are connected in wyes and delta while single-phase loads are connected line-to-ground or line to-line. All loads are modeled as constant kW and kVAr (PQ), constant impedance (Z) or constant current (I) [4, 6].

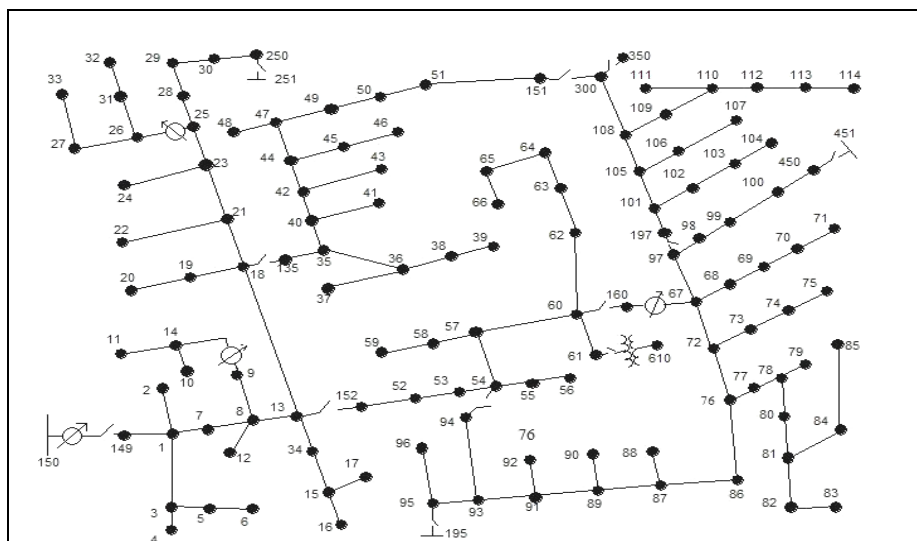

Fig 1: IEEE 123 Node test feeder

Implementation of 123 node feeder in RTDS

So for simulating the 123 node feeder we have to divide it in 6 subsystems. Each sub system is interlinked with a

transmission line. Modeling of overhead line between nodes is done with the help of PI section model.

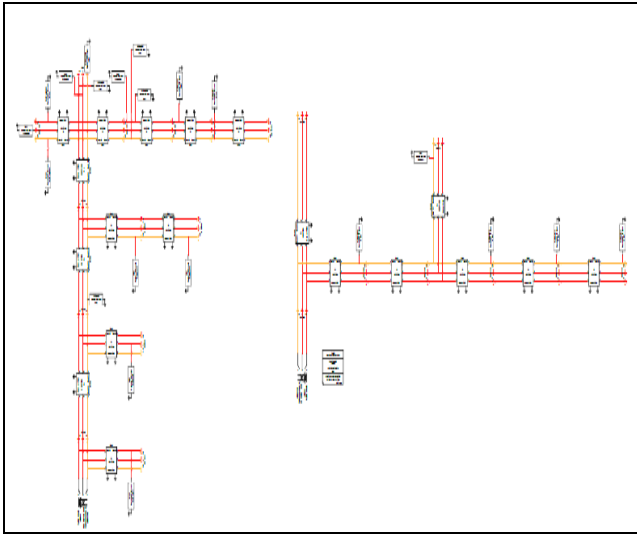

Fig 2: Simulation draft of sub system no 1

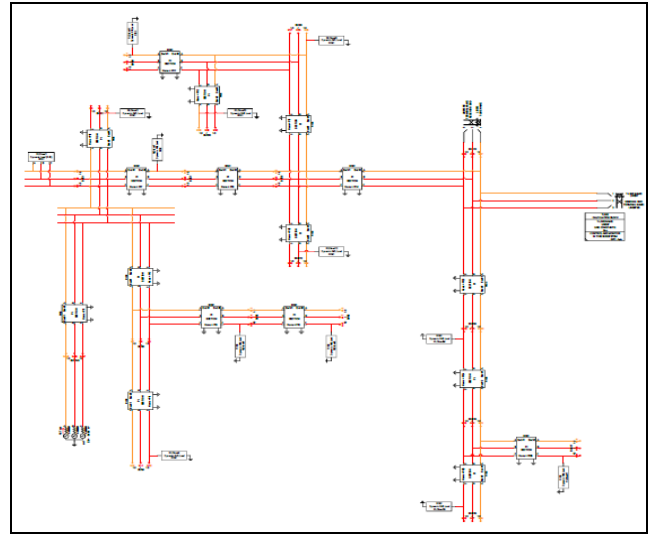

Fig 3: Simulation draft of sub system no 2

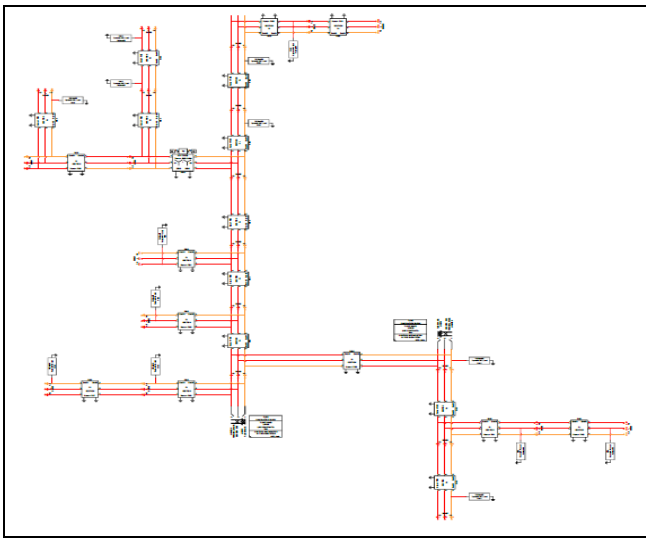

Fig 4: Simulation draft of sub system no 3

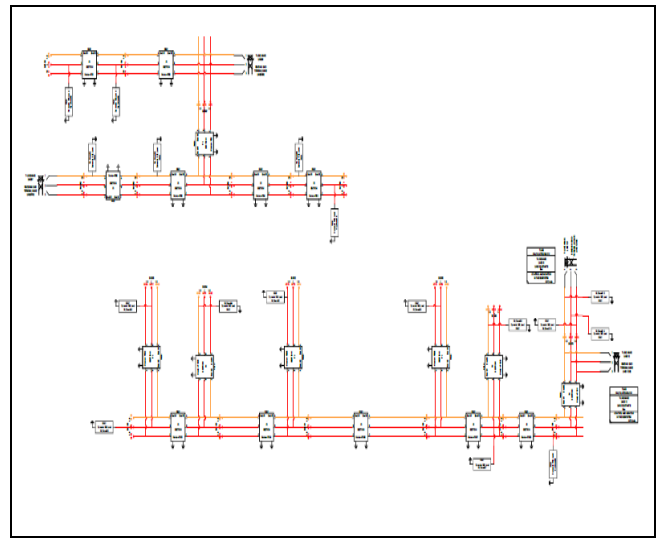

Fig 5: Simulation draft of sub system no 4

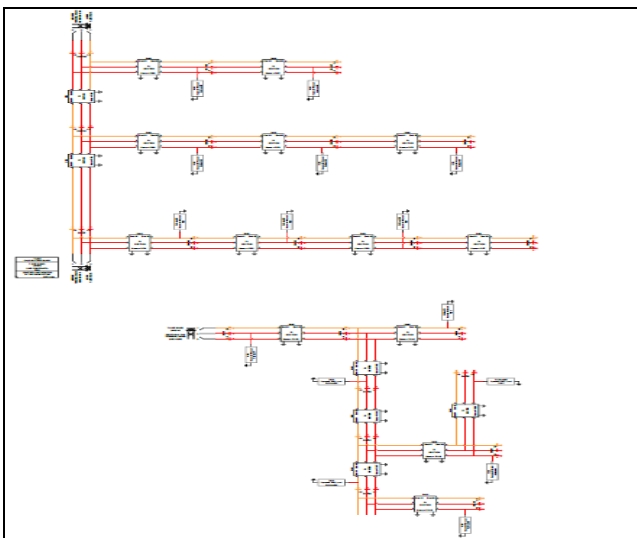

Fig 6: Simulation draft of sub system no 5

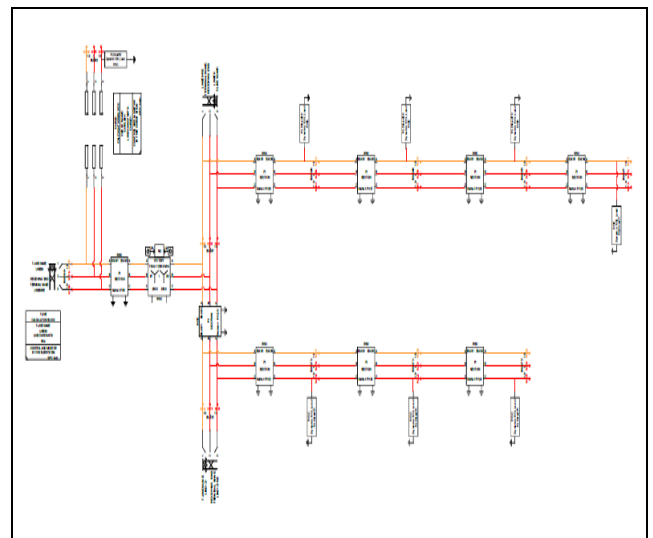

Fig 7: Simulation draft of sub system no 6

Inter connecting nodes and transmission lines
All the 6 subsystems are connected with the help of

transmission line model for continuous power flow between them.

Table 1: List of enter connection between subsystems

Name of subsystem	Name of nodes connecting with T-line	T- line name
1-6	13 and 18	Line 15
1-4	40 and 35	Line 43
3-5	52 and 152	Line 98
2-5	57 and 60	Line 89
5-6	76 and 77	Line 112
2-6	67 and 97	Line 79
1-6	105 and 108	Line 65

Node voltage plots at selected nodes

In this paper 13 nodes are taken for plotting the node voltage graph. These nodes are selected from the critical positions of the sub systems. From sub system 1 node 110, 51 and 42 are plotted. From sub system 2 nodes 7, 11, and 17 are plotted. From sub system 3 nodes 37 and 20 are plotted. From sub system 4 nodes 59 and 88 are plotted. From sub system 5 nodes 85 and 107 are plotted. From sub system 6 nodes 75 is plotted.

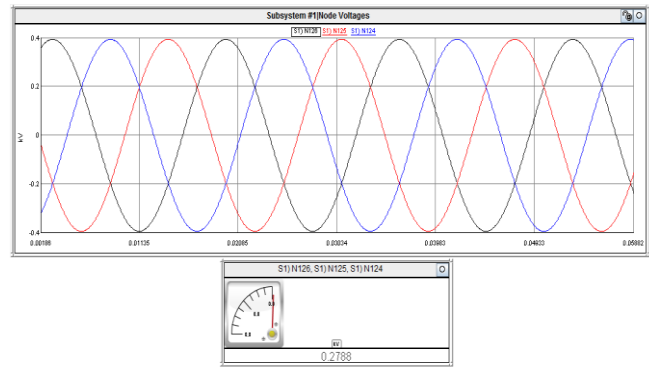

Fig 10: Voltage plot and rms voltage of node no. 42 of subsystem 1

Voltage plot for node no 42. Node no 42 comes in sub system 1 of the 123 node test feeder draft. Every 3 phase node has 3 single nodes. Three single nodes are 126, 125 and 124. RMS value of the voltage is 278.8 volts.

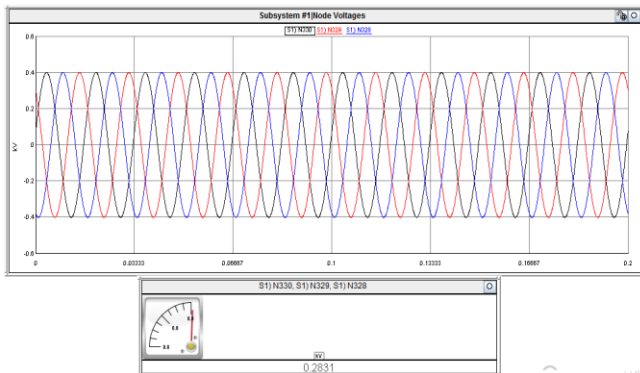

Fig 8: Voltage plot and rms voltage of node no. 110 of subsystem 1

Voltage plot for node no 110. Node no 110 comes in sub system 1 of the 123 node test feeder draft. Every 3 phase node has 3 single nodes. Three single nodes are 330, 329 and 328. RMS value of the voltage is 283.1 volts.

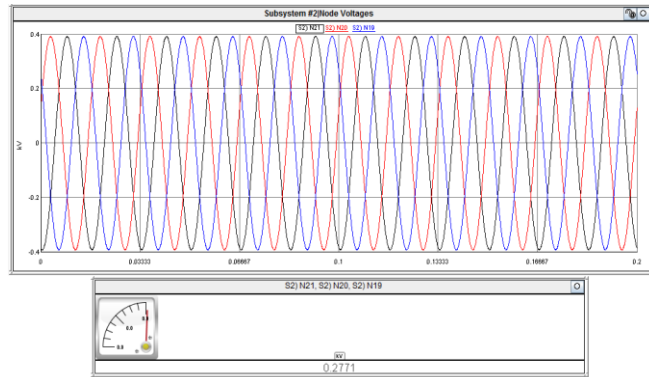

Fig 11: Voltage plot and rms voltage of node no. 7 of subsystem 2

Voltage plot for node no 7. Node no 7 comes in sub system 2 of the 123 node test feeder draft. Every 3 phase node has 3 single nodes. Three single nodes are 21, 20 and 19. RMS value of the voltage is 277.1 volts.

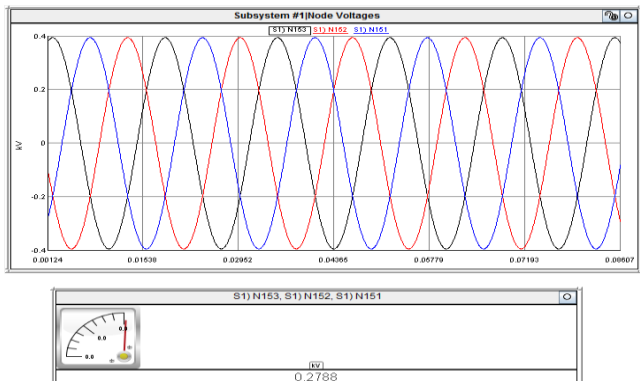

Fig 9: Voltage plot and rms voltage of node no. 51 of subsystem 1

Voltage plot for node no 51. Node no 51 comes in sub system 1 of the 123 node test feeder draft. Every 3 phase node has 3 single nodes. Three single nodes are 153, 152 and 151. RMS value of the voltage is 278.8 volts.

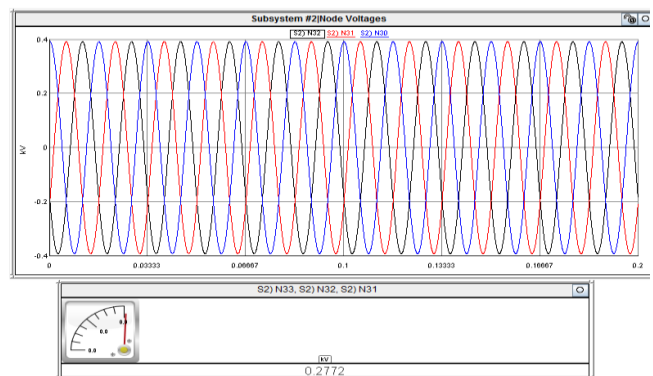

Fig 12: Voltage plot and rms voltage of node no. 11 of subsystem 2

Voltage plot for node no 11. Node no 11 comes in sub system 2 of the 123 node test feeder draft. Every 3 phase node has 3 single nodes. Three single nodes are 33, 32 and 31. RMS value of the voltage is 277.2 volts.

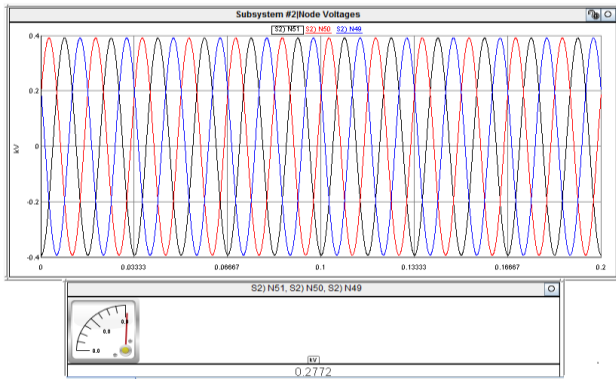

Fig 13: Voltage plot and rms voltage of node no. 17 of subsystem2

Voltage plot for node no 17. Node no 17 comes in sub system 2 of the 123 node test feeder draft. Every 3 phase node has 3 single nodes. Three single nodes are 51, 50 and 49. RMS value of the voltage is 277.2 volts.

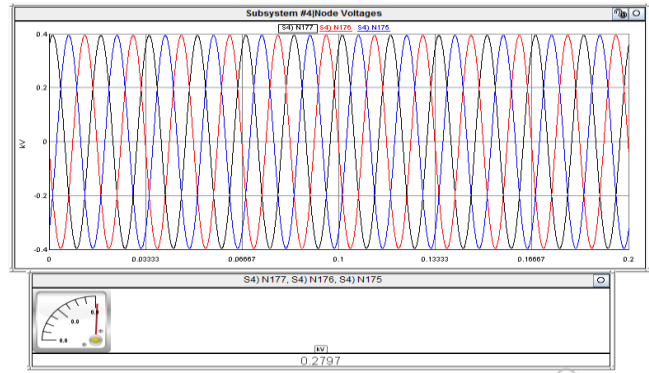

Fig 16: Voltage plot and rms voltage of node no. 59 of subsystem 4

Voltage plot for node no 59. Node no 59 comes in sub system 4 of the 123 node test feeder draft. Every 3 phase node has 3 single nodes. Three single nodes are 177, 176 and 175. RMS value of the voltage is 279.7 volts.

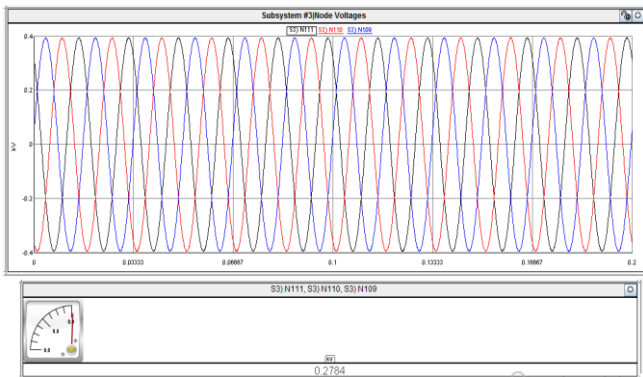

Fig 14: Voltage plot and rms voltage of node no. 37 of subsystem 3

Voltage plot for node no 37. Node no 37 comes in sub system 3 of the 123 node test feeder draft. Every 3 phase node has 3 single nodes. Three single nodes are 111, 110 and 109. RMS value of the voltage is 278.4 volts.

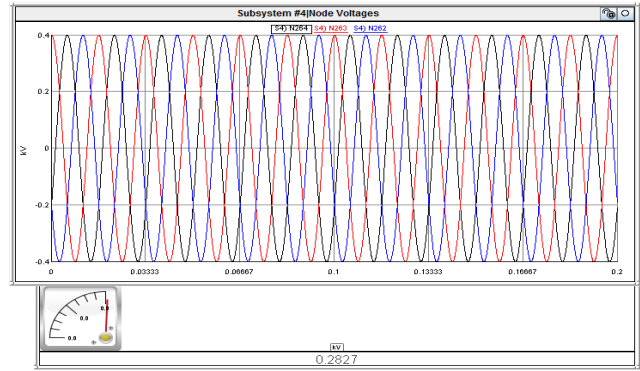

Fig 17: Voltage plot and rms voltage of node no. 88 of subsystem 4

Voltage plot for node no 88. Node no 88 comes in sub system 4 of the 123 node test feeder draft. Every 3 phase node has 3 single nodes. Three single nodes are 264, 263 and 262. RMS value of the voltage is 282.7 volts.

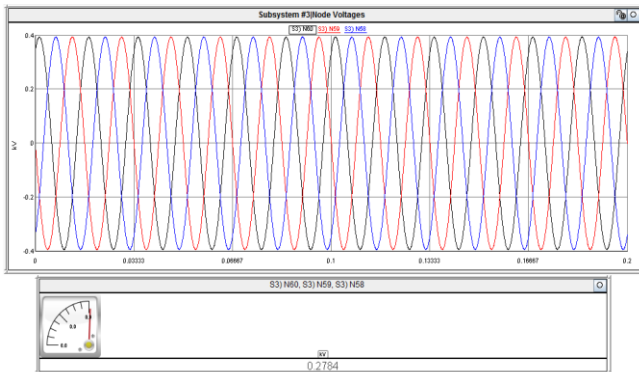

Fig 15: Voltage plot and rms voltage of node no. 20 of subsystem

Voltage plot for node no 20. Node no 20 comes in sub system 3 of the 123 node test feeder draft. Every 3 phase node has 3 single nodes. Three single nodes are 60, 59 and 58. RMS value of the voltage is 278.4 volts.

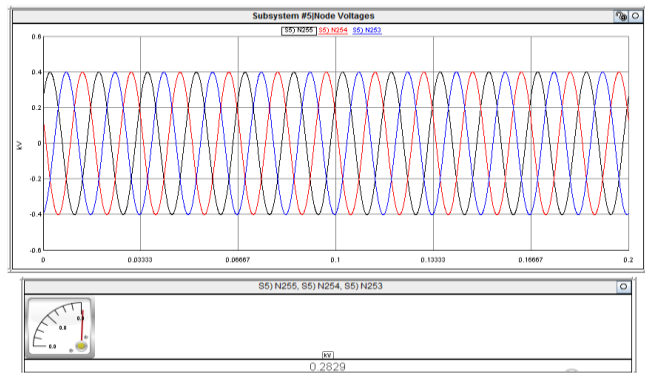

Fig 18: Voltage plot and rms voltage of node no. 85 of subsystem 5

Voltage plot for node no 85. Node no 85 comes in sub system 5 of the 123 node test feeder draft. Every 3 phase node has 3 single nodes. Three single nodes are 255, 254 and 253. RMS value of the voltage is 278.8 volts.

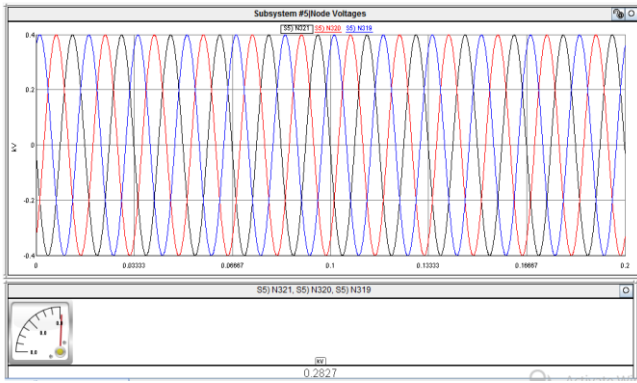

Fig 19: Voltage plot and rms voltage of node no. 107 of subsystem 5

Voltage plot for node no 107. Node no 107 comes in sub system 5 of the 123 node test feeder draft. Every 3 phase node has 3 single nodes. Three single nodes are 321, 320 and 319. RMS value of the voltage is 282.7 volts.

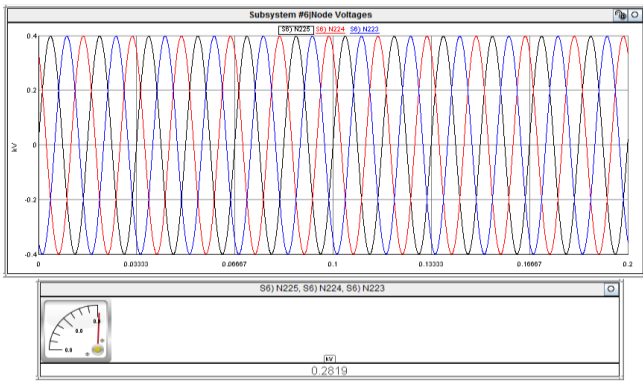

Fig 20: Voltage plot and rms voltage of node no. 75 of subsystem 6

Voltage plot for node no 75. Node no 75 comes in sub system 6 of the 123 node test feeder draft. Every 3 phase node has 3 single nodes. Three single nodes are 225, 224 and 223. RMS value of the voltage is 281.9 volts.

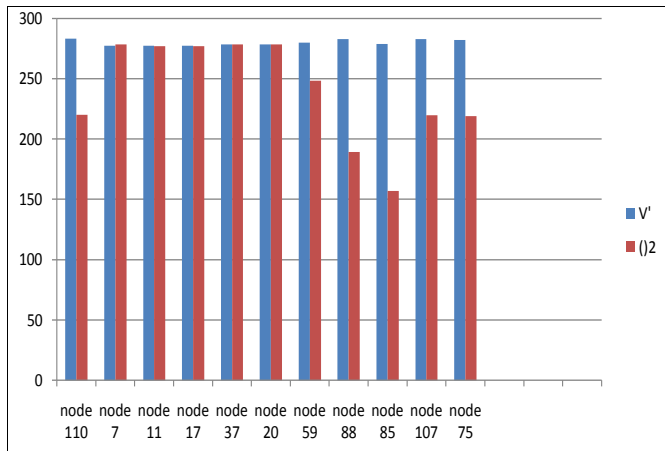

Fig 21: Variation in voltage at initial load and after increments in load on nodes

From the figure and voltage table we can see that voltage fall in large magnitude at node 110, 59, 88, 85, 107 and 75. Node 85 and 88 are more affected when load

increases at node 85. We can see from the figure 3-1 that those nodes are more affected, which are closer to the node 85. So we can conclude that when we increase the load to greater extend there will be fall in operating voltage at that and nearby nodes. This fall in voltage is depends on the load increment.

Conclusion and future scope

Table 2: Comparison of the node voltages, at normal loading and after increment of load

Name of nodes Name of node	Initial voltage (V)	Voltage after increment in load(V')
110	283.1	220.1
7	277.1	278.2
11	277.2	277.0
17	277.2	277.0
37	278.4	278.2
20	278.4	278.2
59	279.7	248.2
88	282.7	189.1
85	278.8	157.0
107	282.7	219.8
75	281.9	219.1

Modeling of 123 node test feeder has been done in RSCAD. Voltage profiles have been plotted for different conditions. From these result we can plan for the future scenario. The main objective of this paper was to get aware with the difficulties of real distribution system. A real distribution system is unbalance type because of unbalance loading and physical configuration of feeder. RTDS is capable to simulate a distribution network in real time. It is very helpful in analyzing and planning a network. RTDS can interact to the external devices. So for knowing the effect of any real device in the system can to be connect it in RTDS with the help of an amplifier. Simulation of the network will give desired parameters. Here the voltage profile for some special cases. These result may be helpful to see a glimpse of real distribution system and can be helpful in analyze the effect of any extension in the system.

This work further can be extended to a real distribution system and can be design and modify a distribution and can analyze it before install it in real world. All the challenges can be simulate in RTDS and we can find the accurate solutions for these challenges. It has been tried to develop an idea for working on real distribution modeling in RTDS. It will be a mile stone for modeling and analyze big distribution systems.

This work further can be extended to a real distribution system. This can be design and modify a distribution and can analyze it before install it in real world. All the challenges can be simulate in RTDS and we can find the accurate solutions for these challenges' tried to develop an idea for working on real distribution modeling in RTDS. I think it will be a mile stone for modeling and analyze big distribution systems to encourage the researchers for work on big systems and go through the difficulties of power system and find solution for them. So there is a bright future of RTDS in power system engineering field.

References

1. Kerstin WH. Distribution system modeling and analysis CRC Press LLC, Boca Raton, Florida, 2002.
2. Real-Time Digital Simulator Users Manual, RTDS Technologies, Winnipeg, Manitoba, Canada, 2012.
3. IEEE Distribution Planning Working Group Report, Radial distribution test feeders, IEEE Transactions on Power Systems. 1991; 6(3):975-985.
4. MATLAB, The Math works, Inc., Natick, MA, USA.
5. Bye on, Gilsung, Season Oh, and Gilsoo Jang. A New DC Offset Removal Algorithm Using an Iterative Method for Real-Time Simulation, IEEE Transactions on Power Delivery, 2011.
6. Ankush Saran. Real time power system simulation using RTDS and NI PXI, 2008 40th North American Power Symposium, 2008.
7. Overhead conductor manual, Southwire Company, Carrollton, GA, 1994.
8. Accurate Modeling of Frequency-Dependent Transmission Lines in Electromagnetic Transients Simulations JR. Marti, IEEE Trans., PAS-101. 1982, 147-157.
9. Transmission Line Models for the Simulation of Interaction Phenomena Between Parallel AC and DC Overhead Lines B, Gustavsen G, Irwin R, Mangelrod D, Brandt K, Kent. Proceedings of the International Conference on Power Systems Transients, IPST99, Budapest, Hungary. 1999, 37-42.
10. Enright W, Nayak OB, Irwin GD, Arrillaga A. An Electromagnetic Transients Model of Multi-Limb Transformer Using Normalized Core Concept, IPST 97 International Conference on Power System Transients, Seattle. 1997; 33:93-98.
11. Enright W, Waston N, Nayak OB. Three Phase five-Limb Unified Magnetic Equivalent Circuit Transformer Models for PSCADV3, IPST 99-International Conference on Power System Transients, Budapest, Hungary. 1999, 462-467.